

COBORDISM OF MORSE MAPS AND ITS APPLICATION TO MAP GERMS

九州大学・大学院数理学研究院 佐伯 修 (OSAMU SAEKI)

Faculty of Mathematics, Kyushu University

ABSTRACT. This is a survey article on cobordism of Morse maps and its application to map germs. Let $f : M \rightarrow S^1$ be a Morse map of a closed manifold M into the circle, where a Morse map is a smooth map with only nondegenerate critical points. In this note, we classify such maps up to fold cobordism. In the course of the classification, we get several fold cobordism invariants for such Morse maps. We also consider a slightly general situation where the source manifold M has boundary and the map f restricted to the boundary has no critical points. Let $g : (\mathbf{R}^m, 0) \rightarrow (\mathbf{R}^2, 0)$, $m \geq 2$, be a generic smooth map germ, where the target \mathbf{R}^2 is oriented. Using the above-mentioned fold cobordism invariants, we show that the number of cusps with a prescribed index appearing in a C^∞ stable perturbation of g , counted with signs, gives a topological invariant of g .

1. INTRODUCTION

Let us consider smooth maps between smooth manifolds. For a set of certain singularity types, Rimányi and Szűcs [19] (see also [24, 25]) established the notion of a cobordism for smooth maps admitting only allowed singularities. Furthermore, they constructed a classifying space for such maps in the case of positive codimensions, where a codimension of a smooth map $f : M \rightarrow N$ refers to $\dim N - \dim M$. This means that the cobordism classification of such maps into a fixed manifold N reduces to the homotopy classification of maps of N (or its one point compactification) into the classifying space. For negative codimensions, similar classifying spaces have been constructed, for example, in [9, 10, 11, 12, 20, 23].

For smooth functions, the simplest singularities are the nondegenerate critical points, and the corresponding maps are the so-called Morse functions. Let us consider nondegenerate critical points and their suspensions, i.e. fold points, as allowed singularities (for details, see §2). Then, the set of corresponding cobordism classes of Morse functions on closed manifolds of a fixed dimension forms a group. This group structure has been completely determined by Ikegami

2000 *Mathematics Subject Classification.* Primary 57R45; Secondary 57R35, 58K30.

Key words and phrases. Morse map, cobordism, critical point, fold, cusp, map germ, stable perturbation.

This is a survey article on the joint work [7] with **Kazuichi Ikegami** (Faculty of Engineering, Hiroshima Institute of Technology).

The author has been partially supported by Grant-in-Aid for Scientific Research (B) (No. 19340018), Japan Society for the Promotion of Science.

in [5] using a geometric method based on the elimination of cusps due to Levine [13], without the use of classifying spaces (see also [6, 8]).

In this note, we first generalize the results for Morse functions to Morse maps; i.e. smooth maps into the circle S^1 with only nondegenerate critical points. The generalizations are straightforward. We also consider a slightly general situation where the manifolds may have boundaries and the maps restricted to the boundaries are submersions.

The main objective of this note is to apply these results to the study of a generic smooth map germ $g : (\mathbf{R}^m, 0) \rightarrow (\mathbf{R}^2, 0)$, $m \geq 2$. It is known that if g is generic enough, then its C^∞ stable perturbation has finitely many cusps. In [3], Fukuda–Ishikawa studied the number of cusps appearing in such a C^∞ stable perturbation when $m = 2$, and showed that the number of cusps modulo two is a topological invariant of the map germ g . In this note, for $m \geq 3$, using an orientation of the target \mathbf{R}^2 , we will define a sign for each cusp (except for cusps of a certain index), and show that the number of cusps of a given index, counted with signs, is an invariant of the target oriented topological type of the map germ g . Here, two map germs have the same target oriented topological type if they are transformed to each other by topological coordinate changes in the source and the target, where the target homeomorphism should preserve the orientation. As a corollary, the absolute value of the number of cusps of a given index, counted with signs, and its modulo two reduction are topological invariants of g . Recall that these results have already been obtained by the second author in [22] for the special case of $m = 3$, using the theory of singular fibers developed in [21].

This note is organized as follows. In §2, we formulate the fold cobordism of Morse maps and their monoids. In §3, we describe the fold cobordism monoid of Morse maps for each dimension, generalizing the results for Morse functions in [5]. We also consider the case where the source manifolds have boundaries, and obtain some fold cobordism invariants. In §4, we consider generic smooth map germs $(\mathbf{R}^m, 0) \rightarrow (\mathbf{R}^2, 0)$ and show that the number of cusps of a given index, counted with signs, appearing in a C^∞ stable perturbation of a given map germ is a target oriented topological invariant. We also give an explicit example of a map germ such that its C^∞ stable perturbation always has an even number of cusps, and the number is always greater than or equal to two. This answers a question raised by Ohsumi [17] in the negative. In §5, we consider generic smooth map germs $(\mathbf{R}^n, 0) \rightarrow (\mathbf{R}^{2n-1}, 0)$ for $n \geq 3$ odd, where the target \mathbf{R}^{2n-1} is oriented. Using a similar idea, we define a sign for each Whitney umbrella, and show that the number of Whitney umbrellas, counted with signs, appearing in a C^∞ stable perturbation of a given map germ is a target oriented topological invariant. This gives an alternative proof of Ohsumi’s results in [16, 17].

This is a survey article, and all the details can be found in the preprint [7], which is a joint work with Ikegami and the author.

Throughout the paper, manifolds and maps are differentiable of class C^∞ unless otherwise indicated. For a topological space X , id_X denotes the identity map of X .

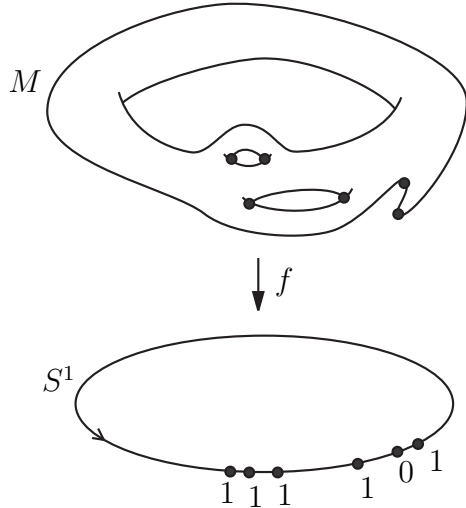

FIGURE 1. An example of a Morse map and the indices of its critical points

The authors would like to express their sincere gratitude to Toshizumi Fukui for explaining details about algebraic formulas and for stimulating discussions. They would also like to thank Mutsuo Oka for his invaluable comments.

2. MORSE MAPS AND THEIR COBORDISMS

Let M be a smooth closed manifold of dimension n and $f : M \rightarrow S^1$ a smooth map. Such a map f is called a *Morse map* if its critical points are all nondegenerate.

In the following, we always assume that the circle S^1 is oriented. Then, each critical point of a Morse map $f : M \rightarrow S^1$ has its own index λ ($0 \leq \lambda \leq n$) (see Fig. 1).

In order to define the notion of a cobordism for Morse maps, let us first recall some terminologies for maps into surfaces. Let W and N be smooth manifolds of dimensions m and 2 respectively, where we assume $m \geq 2$. For a smooth map $F : W \rightarrow N$, a point $p \in W$ is called a *singular point* if the derivative $dF_p : T_p W \rightarrow T_{F(p)} N$ is not surjective. We denote by $S(F)$ the set of singular points of F . A singular point p is called a *fold point* if there exist local coordinates $(u, x_1, x_2, \dots, x_{m-1})$ and (V, Y) around p and $F(p)$, respectively, such that

$$(V \circ F, Y \circ F) = \left(u, -\sum_{i=1}^{\lambda} x_i^2 + \sum_{i=\lambda+1}^{m-1} x_i^2 \right).$$

We call $\max\{\lambda, (m-1) - \lambda\}$ the *index* of p , which does not depend on a particular choice of the local coordinates.

Note that around a fold point, the map F looks like a trivial 1-parameter family of nondegenerate critical points. In other words, a fold point is a suspension of a nondegenerate critical point of a smooth function, where the *suspension* of a map $h : P \rightarrow Q$ between manifolds means the map $h \times \text{id}_{\mathbf{R}} : P \times \mathbf{R} \rightarrow Q \times \mathbf{R}$. In particular, the set $S(F)$ is a regular 1-dimensional submanifold of W around

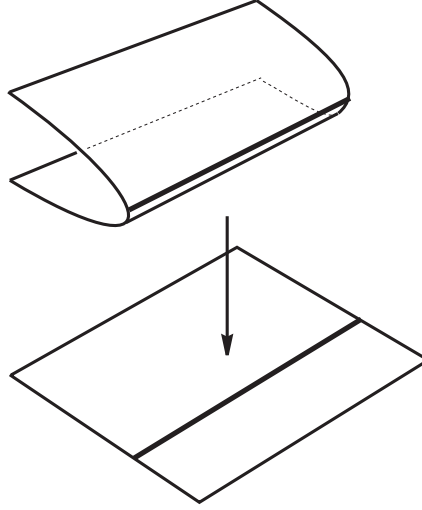

FIGURE 2. Map along a fold curve

a fold point and all the nearby singular points are fold points of the same index (see Fig. 2). The set of fold points is often called a *fold curve*.

A singular point p of $F : W \rightarrow N$ is called a *cuspl* if there exist local coordinates $(u_1, u_2, x_1, x_2, \dots, x_{m-2})$ and (V, Y) around p and $F(p)$, respectively, such that

$$(V \circ F, Y \circ F) = \left(u_1, u_1 u_2 + u_2^3 - \sum_{i=1}^{\lambda} x_i^2 + \sum_{i=\lambda+1}^{m-2} x_i^2 \right).$$

We call $\max\{\lambda, (m-2) - \lambda\}$ the *index* of p , which does not depend on a particular choice of the local coordinates.

Note that around a cuspl, the map F looks like a birth-death of a pair of critical points. The subset $S(F)$ is a regular 1-dimensional submanifold of W around a cuspl and there are two adjacent curves consisting of fold points (see Fig. 3). If the index λ of a cuspl is not equal to $(m-2)/2$, then the adjacent fold curves have indices λ and $\lambda+1$, while in the case of $\lambda = (m-2)/2$, both of the fold curves have index $m/2$.

It is classically known that any smooth map $W \rightarrow N$ can be approximated by a smooth map with only fold points and cuspls as its singularities (see [26]).

Now, let us define the notion of a cobordism for Morse maps.

Definition 2.1. Let $f_i : M_i \rightarrow S^1$ be Morse maps of closed n -dimensional manifolds, $i = 0, 1$. We say that f_0 and f_1 are *fold cobordant* if there exist a compact $(n+1)$ -dimensional manifold X and a smooth map $F : X \rightarrow S^1 \times [0, 1]$ with only fold points as its singularities such that the boundary ∂X is identified with the disjoint union $M_0 \cup M_1$,

$$\begin{aligned} F|_{M_0 \times [0, \varepsilon]} &= f_0 \times \text{id}_{[0, \varepsilon]} : M_0 \times [0, \varepsilon] \rightarrow S^1 \times [0, \varepsilon], \quad \text{and} \\ F|_{M_1 \times (1-\varepsilon, 1]} &= f_1 \times \text{id}_{(1-\varepsilon, 1]} : M_1 \times (1-\varepsilon, 1] \rightarrow S^1 \times (1-\varepsilon, 1] \end{aligned}$$

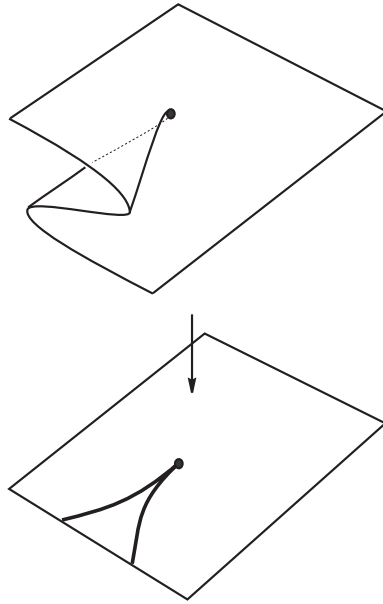

FIGURE 3. Map around a cusp

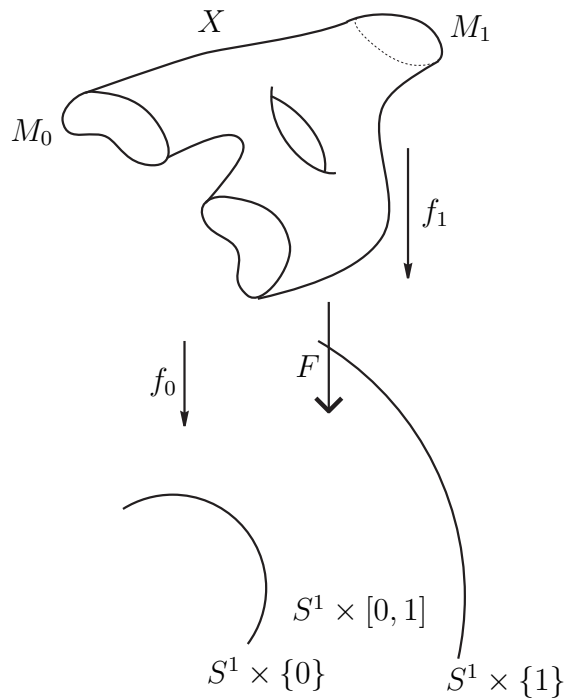

FIGURE 4. A fold cobordism

for some sufficiently small $\varepsilon > 0$, where we identify collar neighborhoods of M_0 and M_1 in X with $M_0 \times [0, \varepsilon)$ and $M_1 \times (1 - \varepsilon, 1]$ respectively (see Fig. 4). In this case, the map F is called a *fold cobordism* between f_0 and f_1 .

Note that this defines a well-defined equivalence relation on the set of all Morse maps on closed manifolds of a fixed dimension.

Let \mathcal{M}_n denote the set of all fold cobordism classes of Morse maps of closed n -dimensional manifolds into S^1 . This obviously has a commutative monoid structure with respect to the disjoint union. We will see later that this forms, in fact, an abelian group.

3. FOLD COBORDISM INVARIANTS

For a Morse map $f : M \rightarrow S^1$ of a closed n -dimensional manifold M and an integer λ with $0 \leq \lambda \leq n$, let $C_\lambda(f)$ denote the number of critical points of f of index λ . We will see later that the following very simple lemma will play an important role.

Lemma 3.1. *Let $f_i : M_i \rightarrow S^1$, $i = 0, 1$, be Morse maps of closed n -dimensional manifolds. If f_0 and f_1 are fold cobordant, then we have*

$$C_\lambda(f_0) - C_{n-\lambda}(f_0) = C_\lambda(f_1) - C_{n-\lambda}(f_1)$$

for all λ with $0 \leq \lambda \leq n$.

By the above lemma, the map $\bar{\varphi}_\lambda : \mathcal{M}_n \rightarrow \mathbf{Z}$ which associates $\varphi_\lambda(f) = C_\lambda(f) - C_{n-\lambda}(f) \in \mathbf{Z}$ to the fold cobordism class $[f]$ represented by a Morse map f is a well-defined homomorphism.

Idea of proof of Lemma 3.1. Let $F : X \rightarrow S^1 \times [0, 1]$ be a fold cobordism between f_0 and f_1 . Note that F has no cusps, the singular point set $S(F)$ of F is a proper 1-dimensional submanifold of X , and $F|_{S(F)}$ is an immersion. Let $\pi : S^1 \times [0, 1] \rightarrow [0, 1]$ be the projection to the second factor. Modifying F if necessary, we may assume that $\pi \circ F|_{S(F)}$ is a Morse function whose critical points have distinct values. For $t \in [0, 1]$, set

$$f_t = F|_{(\pi \circ F)^{-1}(t)} : (\pi \circ F)^{-1}(t) \rightarrow S^1 \times \{t\},$$

which is a Morse map as long as t is a regular value of $\pi \circ F$. As t moves from 0 to 1, it passes through a finite number of critical values. If there is no critical values, then it is easy to verify the required equality. Suppose $t_0 \in [0, 1]$ is a critical value and let us move t from $t_0 - \varepsilon$ to $t_0 + \varepsilon$ for a sufficiently small $\varepsilon > 0$. Then, this corresponds to a creation or a cancelling of a pair of critical points whose indices are λ and $n - \lambda$ for some λ (see Fig. 5). This observation implies that the function $C_\lambda(f_t) - C_{n-\lambda}(f_t)$ does not depend on t as long as t is a regular value. Thus we have the desired equality. \square

Let $\mathfrak{N}_n(S^1)$ denote the *bordism group* of continuous maps of closed manifolds of dimension n into S^1 (see [1], for example). Note that this is a classical object in differential topology and its structure is completely known. Furthermore, let $\omega : \mathcal{M}_n \rightarrow \mathfrak{N}_n(S^1)$ be the natural map forgetting the singularities. The first main theorem of this note is the following.

Theorem 3.2. *The map*

$$(\omega, \bar{\varphi}_{\lfloor (n+3)/2 \rfloor}, \bar{\varphi}_{\lfloor (n+3)/2 \rfloor + 1}, \dots, \bar{\varphi}_n) : \mathcal{M}_n \rightarrow \mathfrak{N}_n(S^1) \oplus \mathbf{Z}^{\lfloor n/2 \rfloor}$$

is an isomorphism, where for a real number x , the symbol $\lfloor x \rfloor$ denotes the greatest integer not exceeding x .

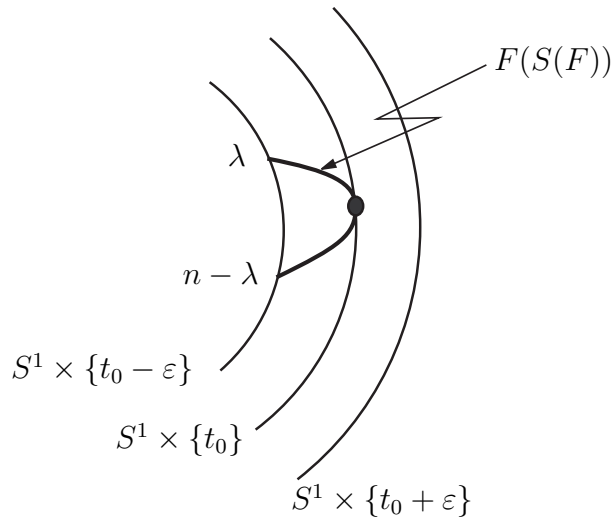

FIGURE 5. Fold cobordism invariance of $C_\lambda - C_{n-\lambda}$

Remark 3.3. A similar result has been obtained by Ikegami [5] for Morse functions. Theorem 3.2 can be proved by adapting Ikegami's method in our setting.

In order to apply our result to the study of map germs, we need to consider Morse maps of manifolds with boundary as follows.

Definition 3.4. Let M be a compact manifold with boundary. A smooth map $f : M \rightarrow S^1$ is a *nice Morse map* if $f|_{\partial M} : \partial M \rightarrow S^1$ is a submersion and the critical points of $f|_{\text{Int } M} : \text{Int } M \rightarrow S^1$ are all nondegenerate.

We can define the notion of a *fold cobordism* for nice Morse maps, where we require that a fold cobordism is a submersion on the boundary cobordism between the boundaries of the source manifolds.

The following lemma can be proved by the same argument as in Lemma 3.1.

Lemma 3.5. *Let $f_i : M_i \rightarrow S^1$, $i = 0, 1$, be nice Morse maps of compact n -dimensional manifolds with boundary. If f_0 and f_1 are fold cobordant, then we have*

$$C_\lambda(f_0) - C_{n-\lambda}(f_0) = C_\lambda(f_1) - C_{n-\lambda}(f_1)$$

for all λ with $0 \leq \lambda \leq n$.

By the above lemma, $\varphi_\lambda(f) = C_\lambda(f) - C_{n-\lambda}(f)$ gives a fold cobordism invariant for each λ .

4. APPLICATION TO MAP GERMS

Let $g : (\mathbf{R}^m, 0) \rightarrow (\mathbf{R}^2, 0)$ be a smooth map germ, $m \geq 2$. We say that g is *generic* if it is cone-like in the following sense, where ε and δ are sufficiently small positive real numbers such that the upper bound of δ depends on g and the upper bound of ε depends on δ and g :

- (G1) $D_\delta^m \cap g^{-1}(S_\varepsilon^1)$ is a smooth manifold possibly with boundary,
- (G2) $g_\partial = g|_{D_\delta^m \cap g^{-1}(S_\varepsilon^1)} : D_\delta^m \cap g^{-1}(S_\varepsilon^1) \rightarrow S_\varepsilon^1$ is a nice Morse map,

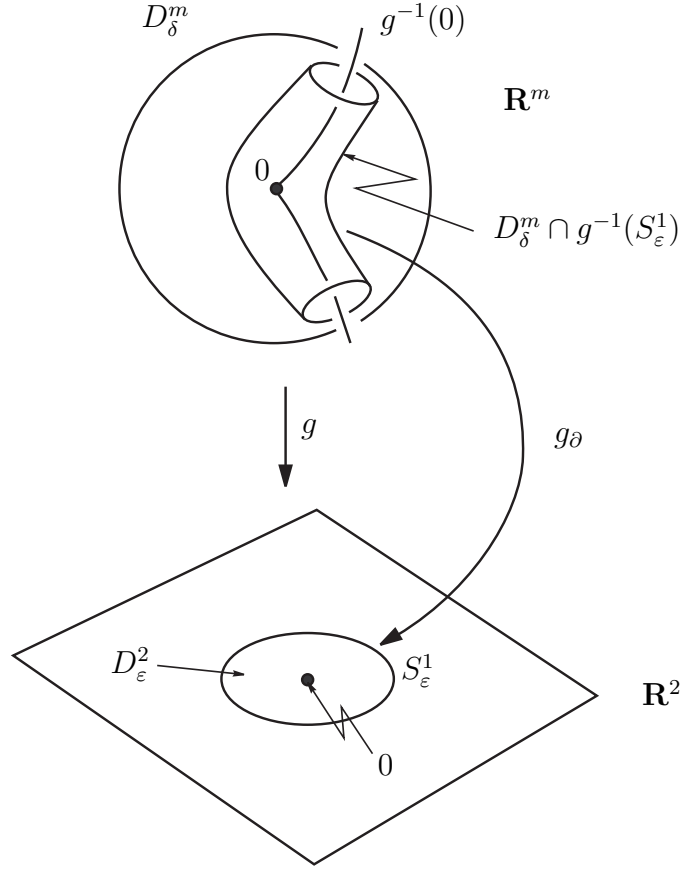

FIGURE 6. A generic map germ

- (G3) $g|_{\partial D_\delta^m \cap g^{-1}(D_\epsilon^2)} : \partial D_\delta^m \cap g^{-1}(D_\epsilon^2) \rightarrow D_\epsilon^2$ is a submersion,
- (G4) $D_\delta^m \cap g^{-1}(D_\epsilon^2)$ is homeomorphic to the m -dimensional disk, and
- (G5) the restriction

$$g|_{D_\delta^m \cap g^{-1}(D_\epsilon^2 \setminus \{0\})} : D_\delta^m \cap g^{-1}(D_\epsilon^2 \setminus \{0\}) \rightarrow D_\epsilon^2 \setminus \{0\}$$

is proper, C^∞ stable and C^∞ equivalent to the product map

$$g_\partial \times \text{id}_{(0, \epsilon]} : (D_\delta^m \cap g^{-1}(S_\epsilon^1)) \times (0, \epsilon] \rightarrow S_\epsilon^1 \times (0, \epsilon],$$

where D_δ^m (or D_ϵ^2) denotes the m -dimensional disk in \mathbf{R}^m (resp. 2-dimensional disk in \mathbf{R}^2) with radius δ (resp. ϵ) centered at the origin (see Fig. 6).

Note that the set of nongeneric map germs has infinite codimension in an appropriate sense. For details, refer to the results of Fukuda [2] or Nishimura [14].

Set $U = D_\delta^m \cap g^{-1}(\text{Int } D_\epsilon^2)$. Then, $g|_U : U \rightarrow \text{Int } D_\epsilon^2$ is a proper smooth map. Let $\tilde{g} = g_t : U \rightarrow \text{Int } D_\epsilon^2$, $0 < |t| \ll 1$, be a C^∞ stable perturbation of $g|_U = g_0$. Note that the singularities of \tilde{g} are fold points and cusps (see Fig. 7).

In general, let $G : W \rightarrow \mathbf{R}^2$ be a smooth map of a manifold with a cusp $p \in W$. We assume that the index λ of p is different from $(m - 2)/2$, where $m = \dim W$. In this situation, we define the *sign* $\text{sign}(p)$ ($= \pm 1$) of p as follows. First we orient \mathbf{R}^2 in the usual way. At the cusp p , the two adjacent fold curves have indices λ and $\lambda + 1$ as mentioned in §2. If their images around $G(p)$ are

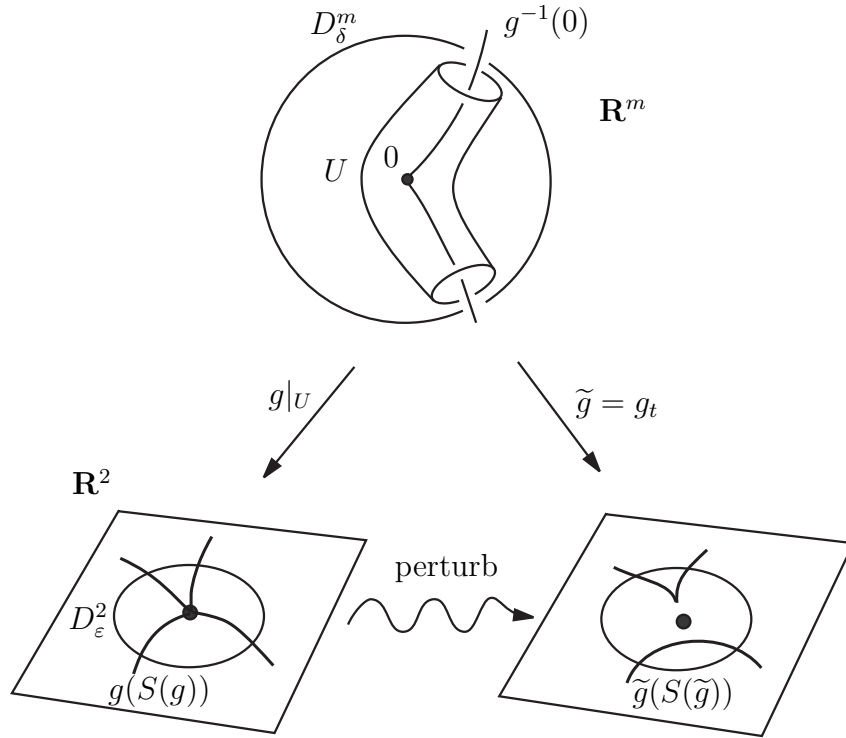

FIGURE 7. A C^∞ stable perturbation of a map germ

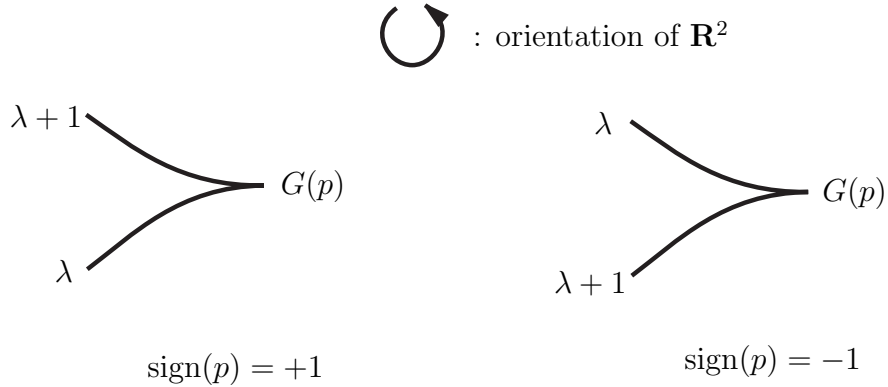

FIGURE 8. Indices of fold curves and the sign of a cusp point p of G

as in the left hand side figure of Fig. 8, then the sign of p is defined to be $+1$ and we call it a *positive cusp*; otherwise, the sign of p is equal to -1 and we call it a *negative cusp*.

By examining the relationship between the number of cusps of a stable perturbation \tilde{g} , counted with signs, and the number of critical points of g_∂ , we obtain the following.

Proposition 4.1. *Let λ be an integer with $\lfloor (m-1)/2 \rfloor \leq \lambda \leq m-2$ and $\lambda \neq (m-2)/2$. Then, the number of cusps of a C^∞ stable perturbation \tilde{g} of*

index λ , counted with signs, is given by

$$\kappa_\lambda(\tilde{g}) = - \sum_{i=\lambda+1}^{m-1} (-1)^{i-\lambda-1} \varphi_i(g_\partial).$$

Note that the terms $\varphi_i(g_\partial)$ appearing on the right hand side are fold cobordism invariants of the nice Morse map g_∂ appearing around $g^{-1}(0)$. This will turn out to be essential in the proof of our main result (Theorem 4.4) in this section.

Remark 4.2. When m is even, the number of cusps of \tilde{g} of index $(m-2)/2$ has the same parity as $1 - \chi(F_g) - \sigma(g_\partial)$, where $\chi(F_g)$ is the Euler characteristic of a Milnor fiber of g , and $\sigma(g_\partial) = C_0(g_\partial) + C_1(g_\partial) + \cdots + C_{(m-2)/2}(g_\partial)$.

Definition 4.3. Let g and $g' : (\mathbf{R}^m, 0) \rightarrow (\mathbf{R}^p, 0)$ be smooth map germs. We say that they are *topologically \mathcal{A} -equivalent* if there exist homeomorphism germs $\Psi : (\mathbf{R}^m, 0) \rightarrow (\mathbf{R}^m, 0)$ and $\psi : (\mathbf{R}^p, 0) \rightarrow (\mathbf{R}^p, 0)$ such that $g' = \psi^{-1} \circ g \circ \Psi$. Furthermore, if the homeomorphism germ ψ can be chosen so that it preserves the orientation of \mathbf{R}^p , then we say that g and g' are *topologically \mathcal{A}_+ -equivalent*.

Our second main result of this note is the following.

Theorem 4.4. *Let $g : (\mathbf{R}^m, 0) \rightarrow (\mathbf{R}^2, 0)$, $m \geq 2$, be a generic smooth map germ and λ an integer with $\lfloor (m-1)/2 \rfloor \leq \lambda \leq m-2$ and $\lambda \neq (m-2)/2$. Then, the number of cusps $\kappa_\lambda(\tilde{g})$ of index λ , counted with signs, of a C^∞ stable perturbation \tilde{g} of a representative of g is an invariant of the topological \mathcal{A}_+ -equivalence class of g . In particular, its absolute value is an invariant of the topological \mathcal{A} -equivalence class of g . Furthermore, when m is even, the parity of the number of cusps of index $(m-2)/2$ is an invariant of the topological \mathcal{A} -equivalence class of g .*

Theorem 4.4 is proved as follows. We first show that the nice Morse maps associated with topologically \mathcal{A}_+ -equivalent map germs are, in a sense, fold cobordant. Then, since the number of cusps appearing in a C^∞ stable perturbation can be described in terms of fold cobordism invariants of the associated nice Morse map by Proposition 4.1, we get the desired conclusion.

Remark 4.5. For the special case of $m = 2$, the above results have been obtained by Fukuda–Ishikawa [3], who used a formula for the number of cusps of a stable map between surfaces due to Quine [18]. For $m = 3$, the above results have been obtained by the author in [22] by using the theory of singular fibers developed in [21].

Remark 4.6. For the total number $\kappa(\tilde{g})$ of cusps modulo two appearing in a C^∞ stable perturbation \tilde{g} of a generic smooth map germ $g : (\mathbf{R}^m, 0) \rightarrow (\mathbf{R}^2, 0)$, there has been known an algebraic formula as follows. Suppose that g is real analytic of corank one, and is \mathcal{K} -finite. Then we have

$$\kappa(\tilde{g}) \equiv \dim_{\mathbf{R}} \mathcal{E}_m / \mathcal{I}(\Sigma^{m-1,1}(g)) \pmod{2},$$

which holds as long as the dimension on the right hand side is finite (see [4, Corollary 4.4]). Here, \mathcal{E}_m is the ring of C^∞ function germs of $(\mathbf{R}^m, 0)$ to \mathbf{R} ,

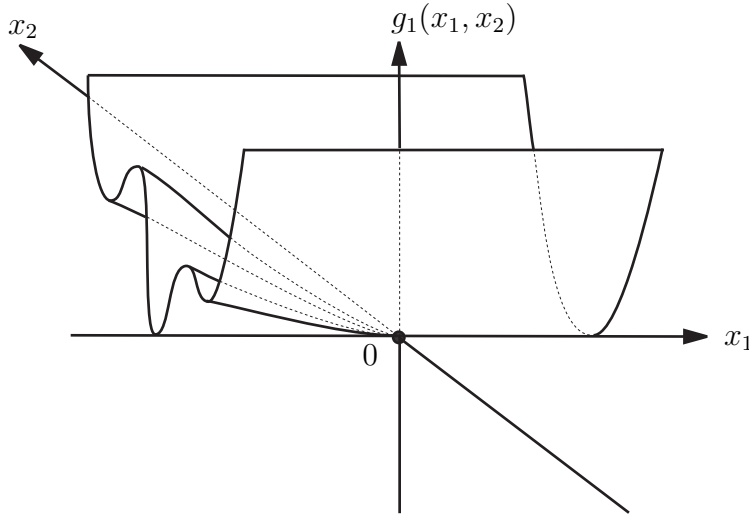

FIGURE 9. The graph of $g_1(x_1, x_2)$

the ideal $\mathcal{I}(\Sigma^{m-1,1}(g))$ is the pull-back of $\mathcal{I}(\Sigma^{m-1,1})$ by the jet extension $j^r g$ of g for a sufficiently large r , and $\mathcal{I}(\Sigma^{m-1,1})$ is the defining ideal of the set germ $\overline{\Sigma^{m-1,1}}$ in $(J^r(\mathbf{R}^m, \mathbf{R}^2), j^r g(0))$, where $\overline{\Sigma^{m-1,1,0}} = \overline{\Sigma^{m-1,1}}$ and $\Sigma^{m-1,1,0}$ is the Boardman submanifold in the jet space corresponding to the cusps. For details, see [3, 4, 15, 16, 17].

We do not know if there is a similar formula for $\kappa_\lambda(\tilde{g}) \in \mathbf{Z}$.

Example 4.7. Let $g : (\mathbf{R}^m, 0) \rightarrow (\mathbf{R}^2, 0)$, $m \geq 3$, be a smooth map germ defined by

$$g(x_1, x_2, \dots, x_m) = \left(x_1, g_1(x_1, x_2) + \sum_{j=3}^m x_j^2 \right),$$

where g_1 is given by

$$g_1(x_1, x_2) = \int_0^{x_2} u(u^2 + x_1 u + x_1)(u^2 + x_1 u + 2x_1) du.$$

The graph of g_1 is as depicted in Fig. 9.

For this example, we can show that the nice Morse map g_∂ has six critical points and that their indices are $0, m-2, m-1, m-2, m-1$ and $m-1$. Therefore, according to Proposition 4.1, we have

$$\kappa_{m-2}(\tilde{g}) = -\varphi_{m-1}(g_\partial) = -(3-1) = -2$$

and $\kappa_\lambda(\tilde{g}) = 0$ for all $\lambda \neq m-2, (m-2)/2$, where \tilde{g} is any C^∞ stable perturbation of g . We can also show, with the help of a computer, that

$$\dim_{\mathbf{R}} \mathcal{E}_m / \mathcal{I}(\Sigma^{m-1,1}(g)) = 12 \equiv 0 \pmod{2}.$$

However, a stable perturbation \tilde{g} always has at least two cusps according to Theorem 4.4. This answers a question raised by Ohsumi [17] in the negative.

For this example, there exists a C^∞ stable perturbation \tilde{g} of g whose singular point set image is as depicted in Fig. 10.

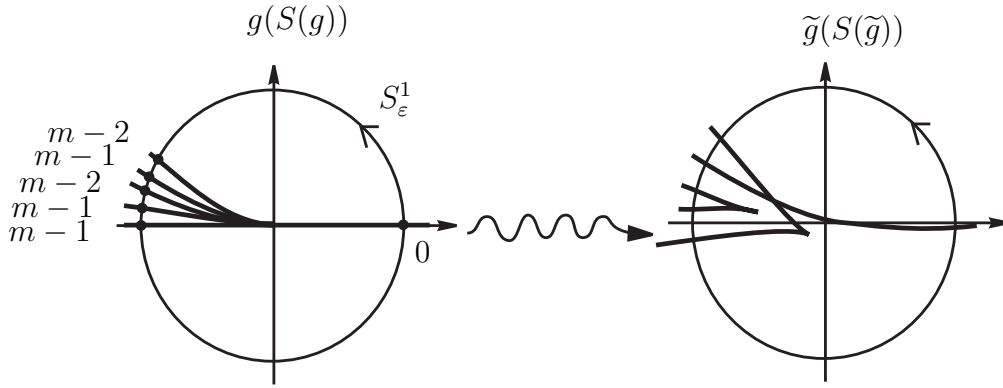

FIGURE 10. An example of a C^∞ stable perturbation of g

5. NUMBER OF WHITNEY UMBRELLAS WITH SIGNS

Let $g : (\mathbf{R}^n, 0) \rightarrow (\mathbf{R}^{2n-1}, 0)$, $n \geq 2$, be a generic smooth map germ, where such a smooth map germ is generic if it is cone-like.

The following theorem has been obtained by Ohsumi [16, 17].

Theorem 5.1 (Ohsumi, 2006). *The number modulo two of Whitney umbrellas appearing in a C^∞ stable perturbation of g is an invariant of the topological \mathcal{A} -equivalence class of g .*

Recall that a singular point $p \in M$ of a smooth map $f : M \rightarrow N$ with $\dim M = n$ and $\dim N = 2n - 1$ is called a *Whitney umbrella* if we can choose local coordinates (x_1, x_2, \dots, x_n) and $(y_1, y_2, \dots, y_{2n-1})$ around p and $f(p)$, respectively, such that f has the form

$$(x_1, x_2, \dots, x_n) \mapsto (x_1, x_2, \dots, x_{n-1}, x_n^2, x_1x_n, x_2x_n, \dots, x_{n-1}x_n).$$

Now, suppose that n is odd and \mathbf{R}^{2n-1} is oriented. Then, we can define a *sign* for a Whitney umbrella using the orientation of \mathbf{R}^{2n-1} . In fact, if N is oriented and if a smooth map $f : M \rightarrow N$ has $p \in M$ as a Whitney umbrella, then $\tilde{S} = f^{-1}(S_\epsilon^{2n-2})$ is diffeomorphic to S^{n-1} and $f|_{\tilde{S}} : \tilde{S} \rightarrow S_\epsilon^{2n-2}$ is an immersion with exactly one transverse double point, where S_ϵ^{2n-2} is a small sphere centered at $f(p)$, and the sign of the double point is defined using the orientation of S_ϵ^{2n-2} (see Fig. 11).

Then, for n odd, the following refinement of Theorem 5.1 holds.

Theorem 5.2. *Suppose that $n \geq 3$ is odd. Then, the number of Whitney umbrellas, counted with signs, appearing in a C^∞ stable perturbation of a generic smooth map germ $g : (\mathbf{R}^n, 0) \rightarrow (\mathbf{R}^{2n-1}, 0)$ is an invariant of the topological \mathcal{A}_+ -equivalence class of g . In particular, its absolute value is an invariant of the topological \mathcal{A} -equivalence class.*

Note that the above absolute value gives a lower bound for the number of Whitney umbrellas appearing in a C^∞ stable perturbation.

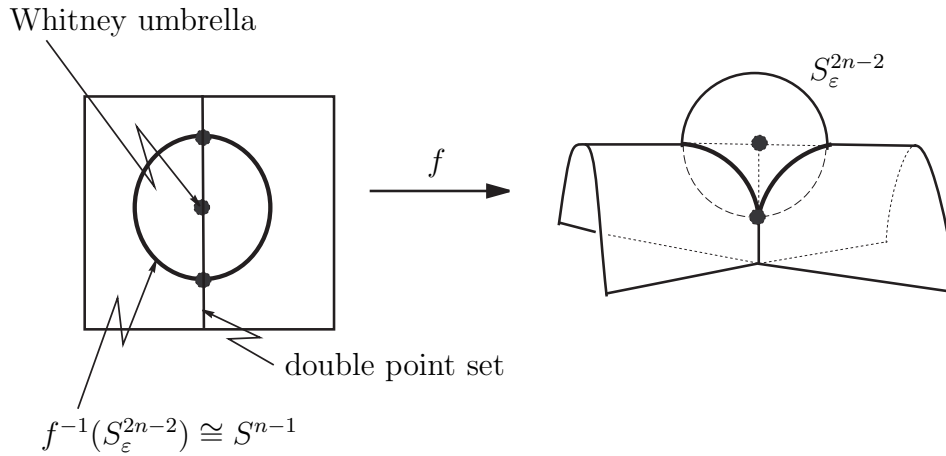

FIGURE 11. A Whitney umbrella and the associated immersion with a double point

REFERENCES

- [1] P.E. Conner and E.E. Floyd, *Differentiable periodic maps*, Ergebnisse der Math. und ihrer Grenzgebiete, Band 33, Springer-Verlag, Berlin, Göttingen, Heidelberg, 1964.
- [2] T. Fukuda, *Local topological properties of differentiable mappings. II*, Tokyo J. Math. **8** (1985), 501–520.
- [3] T. Fukuda and G. Ishikawa, *On the number of cusps of stable perturbations of a plane-to-plane singularity*, Tokyo J. Math. **10** (1987), 375–384.
- [4] T. Fukui, J.J. Nuño Ballesteros and M.J. Saia, *On the number of singularities in generic deformations of map germs*, J. London Math. Soc. (2) **58** (1998), 141–152.
- [5] K. Ikegami, *Cobordism group of Morse functions on manifolds*, Hiroshima Math. J. **34** (2004), 211–230.
- [6] K. Ikegami and O. Saeki, *Cobordism group of Morse functions on surfaces*, J. Math. Soc. Japan **55** (2003), 1081–1094.
- [7] K. Ikegami and O. Saeki, *Cobordism of Morse maps and its application to map germs*, preprint, 2007.
- [8] B. Kalmár, *Cobordism group of Morse functions on unoriented surfaces*, Kyushu J. Math. **59** (2005), 351–363.
- [9] B. Kalmár, *Pontryagin-Thom construction for singular maps with negative codimension*, Master Thesis, Eötvös Loránd Univ., 2005, <http://www.cs.elte.hu/math/diploma/math/>.
- [10] B. Kalmár, *Pontryagin-Thom type construction for negative codimensional singular maps*, arXiv:math/0612116v1 [math.GT].
- [11] B. Kalmár, *Fold maps, their geometric invariants, and computations of cobordism groups*, PhD Thesis, Kyushu University, 2008.
- [12] M. Kazarian, *Thom polynomials*, Singularity theory and its applications, Edited by S. Izumiya, G. Ishikawa, H. Tokunaga, I. Shimada and T. Sano, Adv. Stud. Pure Math. **43** (2007), 85–135.
- [13] H.I. Levine, *Elimination of cusps*, Topology **3** (1965), suppl. 2, 263–296.
- [14] T. Nishimura, *Topologically ∞ -determined map germs are topologically cone-like*, Compositio Math. **64** (1987), 117–129.
- [15] J.J. Nuño Ballesteros and M.J. Saia, *Multiplicity of Boardman strata and deformations of map germs*, Glasgow Math. J. **40** (1998), 21–32.
- [16] M. Ohsumi, *Whitney’s umbrellas in stable perturbations of a map germ $(\mathbf{R}^n, 0) \rightarrow (\mathbf{R}^{2n-1}, 0)$* , Tokyo J. Math. **29** (2006), 475–493.

- [17] M. Ohsumi, *Singularities appearing in a stable perturbation of a map-germ*, Real and complex singularities, Proceedings of the Australian–Japanese Workshop, World Scientific, 2007, pp. 323–341.
- [18] J.R. Quine, *A global theorem for singularities of maps between oriented 2-manifolds*, Trans. Amer. Math. Soc. **236** (1978), 307–314.
- [19] R. Rimányi and A. Szűcs, *Pontrjagin-Thom-type construction for maps with singularities*, Topology **37** (1998), 1177–1191.
- [20] R. Sadykov, *Bordism groups of solutions to differential relations*, preprint, June 2004, revised form in arXiv:math/0608460v1 [math.AT].
- [21] O. Saeki, *Topology of singular fibers of differentiable maps*, Lecture Notes in Math., Vol. 1854, Springer–Verlag, Berlin, Heidelberg, 2004.
- [22] O. Saeki, *Cobordism of Morse functions on surfaces, the universal complex of singular fibers and their application to map germs*, Algebr. Geom. Topol. **6** (2006), 539–572.
- [23] O. Saeki and T. Yamamoto, *Singular fibers and characteristic classes*, Topology Appl. **155** (2007), 112–120.
- [24] A. Szűcs, *Analogue of the Thom space for mappings with singularity of type Σ^1* (in Russian), Mat. Sb. (N.S.) **108 (150)** (1979), 433–456, 478; English translation in Math. USSR-Sb. **36** (1980), 405–426.
- [25] A. Szűcs, *Cobordism of singular maps*, preprint, 2006, revised form in arXiv:math/0612152v2 [math.GT].
- [26] H. Whitney, *On singularities of mappings of Euclidean spaces I; mappings of the plane into the plane*, Ann. of Math. **62** (1955), 374–410.

FACULTY OF MATHEMATICS, KYUSHU UNIVERSITY, HAKOZAKI, FUKUOKA 812-8581,
JAPAN

E-mail address: saeki@math.kyushu-u.ac.jp